

# CENTER - PULL HOIST RING

**Safe Mold Lifting at any angle**

**Full 360° Swivel**  
**Full 180° Pivot**

**Quality Standards**

- All hoist ring assemblies are pull-tested and certified to 200% of rated load capacity and stamped with identifying date code.
- All hoist rings are designed for 5:1 strength factor.
- Finished assembly is black-oxide plated (with the exception of the washer).
- Individual certificate of proof-test accompanies product in final packaging.



**SPECIFICATIONS**

- Material: Alloy Steel
- Finish: Black Oxide
- Clevis, Bolt, Pins, Base, Washer and Bushing are magnetic-particle inspected based on ASTM709-80 and MIL-STD-105
- Washer: Gold Iridite
- 200% Proof Tested

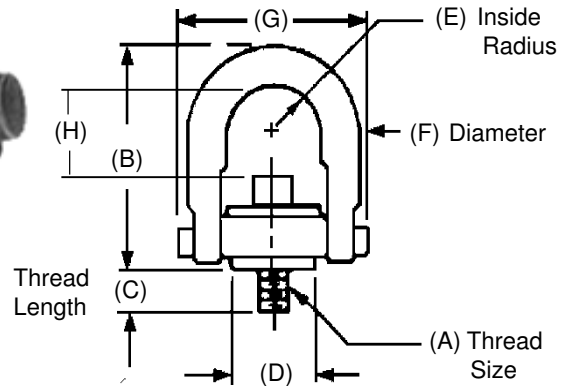

THRD SIZE A	LOAD CAP (lbs)	PART #	THREAD LENGTH							TORQUE (ft.-lbs.)	WT. (lbs.)	PRICE
			B	C	D	E	F	G	H			
5/16-18	800	<b>23406</b>	2.67	9/16	.75	.43	.38	1.84	1-1/4	7	.3	<b>\$86.05</b>
3/8-16	1000	<b>23408</b>	2.67	9/16	.75	.43	.38	1.84	1-1/4	12	.3	<b>\$86.05</b>
1/2-13	2500	<b>23412</b>	4.78	1	1.50	.88	.75	3.52	2-3/8	28	2.5	<b>\$103.60</b>
1/2-13	2500	<b>23413</b>	4.78	1-1/4	1.50	.88	.75	3.52	2-3/8	28	2.5	<b>\$103.60</b>
5/8-11	4000	<b>23414</b>	4.78	1	1.50	.88	.75	3.52	2-1/4	60	2.7	<b>\$103.60</b>
5/8-11	4000	<b>23415</b>	4.78	1-1/4	1.50	.88	.75	3.52	2-1/4	60	2.7	<b>\$103.60</b>
3/4-10	5000	<b>23417</b>	4.78	1	1.50	.88	.75	3.52	2-1/8	100	3.0	<b>\$103.60</b>
3/4-10	5000	<b>23418</b>	4.78	1-1/2	1.50	.88	.75	3.52	2-1/8	100	3.0	<b>\$103.60</b>
7/8-9	8000	<b>23424</b>	6.52	1-1/4	2.31	1.40	1.00	5.14	2-13/16	160	7.5	<b>\$221.25</b>
1-8	10000	<b>23425</b>	6.52	1-1/4	2.31	1.40	1.00	5.14	2-11/16	230	7.5	<b>\$221.25</b>
1-8	10000	<b>23426</b>	6.52	1-1/2	2.31	1.40	1.00	5.14	2-11/16	230	7.5	<b>\$221.25</b>
1-1/4-7	15000	<b>23429</b>	8.73	1-7/8	3.19	1.75	1.25	6.50	4-1/4	470	14	<b>\$377.25</b>
1-1/2-6	24000	<b>23433</b>	12.47	2-3/4	4.19	2.25	1.75	8.55	6-1/2	800	33	<b>\$496.60</b>

**Metric sizes available . . . SEE PAGE 205**

© 2019 MOLDERS CHOICE, Inc.



24 Hour Service - 7 Days a week

## 1-800-809-4623

WebSite: [www.molderschoice.com](http://www.molderschoice.com) • Email: [molders@molderschoice.com](mailto:molders@molderschoice.com)

# METRIC CENTER - PULL HOIST RING

*Safe Mold Lifting at any angle*

**Full 360° Swivel**  
**Full 180° Pivot**

**Quality Standards**

- All hoist ring assemblies are pull-tested and certified to 200% of rated load capacity and stamped with identifying date code.
- All hoist rings are designed for 5:1 strength factor.
- Finished assembly is black-oxide plated (with the exception of the washer).
- Individual certificate of proof-test accompanies product in final packaging.



**SPECIFICATIONS**

- Material: 4140
- Finish: Black Oxide
- Clevis, Bolt, Pins, Base, Washer and Bushing are magnetic-particle inspected based on ASTM709-80 and MIL-STD-105
- Washer: Zin Plated Silver
- 200% Proof Tested

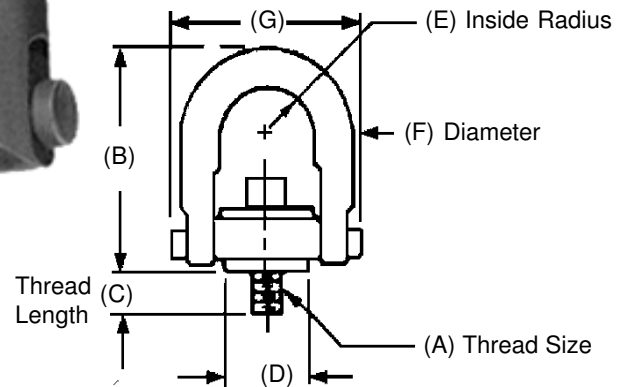

THRD SIZE A	LOAD CAP (lbs)	PART #	THREAD LENGTH						TORQUE (ft.-lbs.)	WT. (lbs.)	PRICE
			B	C	D	E	F	G			
M8X1.25	400	23456	67.8	12.5	19	10.9	9.7	46.7	1	0.17	\$86.05
M10X1.5	450	23458	67.8	17.5	19	10.9	9.7	46.7	1.7	0.17	\$86.05
M12X1.75	1050	23462	170	19	1.50	22.4	19	89.4	3.8	1.08	\$103.60
M16X20	1900	23465	121.4	29	1.50	22.4	19	89.4	8.2	1.12	\$106.60
M20X2.5	2150	23468	121.4	34	1.50	22.4	19	89.4	13.6	1.19	\$106.60
10620X2.5	3000	23471	165.6	32	1.50	35.6	25.4	130.6	13.6	3.03	\$221.25
M24X3.0	4200	23474	165.6	37	1.50	35.6	25.4	130.6	31	3.1	\$221.25
M30X3.5	7000	23478	221.7	41.9	1.50	44.5	31.7	165.1	60	6.3	\$377.25
M30X.5	7000	23479	221.7	61.7	2.31	44.5	31.7	165.1	60	6.4	\$377.25
M36X4.0	11000	23483	316.7	63.5	2.31	57.2	44.4	217.2	100	15.5	\$496.60
M42X4.5	12500	23484	316.7	68	2.31	57.2	44.4	217.2	100	16	\$579.40
M48X5.0	13500	23485	316.7	82.4	3.19	57.2	44.4	217.2	100	16.8	\$611.35
M64X6.0	22500	23488	419.1	101.6	4.19	76.2	57.15	297.6	209	40	\$1586.70

©2019 MOLDERS CHOICE, Inc.



**24 Hour Service - 7 Days a week**  
**1-800-809-4623**  
WebSite: [www.molderschoice.com](http://www.molderschoice.com) • Email: [molders@molderschoice.com](mailto:molders@molderschoice.com)

# Tamper Resistant SWIVEL EYEBOLT

Installs permanently on your mold to help ensure safe lifting



Special Installation Tool required – helps prevent unauthorized removal

The same advantages and specifications as our Center-Pull Hoist Ring, but Tamper resistant

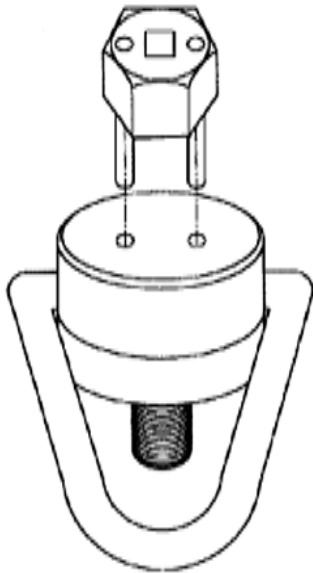

(2) HOLES FOR 3/16 or 5mm DIAMETER PINS ON INSTALLATION TOOL

TO PREVENT BINDING, THE MOUNTING HOLE COUNTERSINK SHOULD NOT EXCEED 'M' DIMENSION

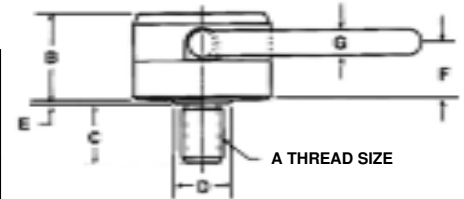
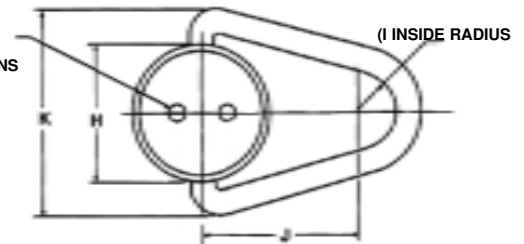
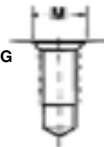

### Pricing

Thread Size	Swivel Eyebolt		Installation Tool	
	PART #	PRICE	PART #	PRICE
3/8-16	47621	\$71.15	47641	\$20.20
1/2-13	47622	\$71.15	47641	\$20.20
5/8-11	47625	\$122.55	47642	\$26.65
3/4-10	47626	\$122.55	47643	\$26.65

### Swivel Eyebolt Specifications

PART #	Torque ft. lbs.	Load Capacity (lbs)	Thread Size A	in Inches (unless specified)										
				B	C	D	E	F	G	H	I	J	K	M
47621	7	1000	3/8-16	1-3/32	9/16	3/4	3/64	45/64	5/16	1-3/4	1/2	2	2-5/8	1/2
47622	20	2000	1/2-13	1-3/32	3/4	3/4	3/64	45/64	5/16	1-3/4	1/2	2	2-5/8	5/8
47625	35	3000	5/8-11	1-1/4	15/16	7/8	3/64	3/4	3/8	2-1/4	5/8	2-1/2	3-1/4	3/4
47626	55	4000	3/4-10	1-33/64	1-1/8	1	1/32	57/64	1/2	2-5/8	3/4	3	3-7/8	7/8

©2019 MOLDERS CHOICE, Inc.



24 Hour Service - 7 Days a week  
**1-800-809-4623**  
 WebSite: [www.molderschoice.com](http://www.molderschoice.com) • Email: [molders@molderschoice.com](mailto:molders@molderschoice.com)

# CENTER - PULL HOIST RING

## INSTALLATION INFORMATION



**Never** use hook or other lifting device which will pry or tend to open the "U" shaped bar on Center-Pull Hoist Rings!

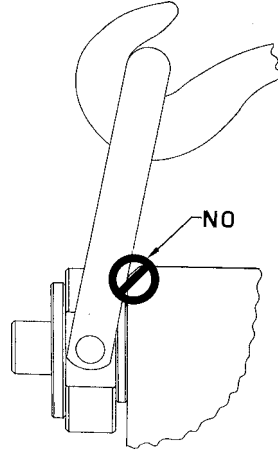

After installation, check the Hoist ring to be sure it swivels and pivots freely in all directions. **The side of the ring must not contact anything!**

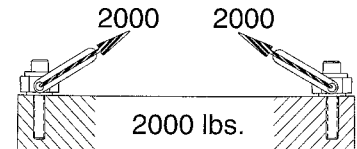

Depending on the sling angle, **the applied load may be more than the weight being lifted.** Two-point lifting of a 2000 pound weight, with a sling angle of 30° will result in applied load of 2000 pounds to **each** hoist ring!

Select the proper Hoist Ring for the job. Do not attempt to apply more than the rated capacity. The *load capacity* is stamped on the *Hoist Ring*.

Drill and tap the workpiece so the hoist ring bolt is installed perpendicular to the surface of the workpiece. Countersink the tapped hole to prevent "swelling" of the top thread when the hoist ring bolt is torqued. The workpiece surface must be flat, providing complete contact for the hoist ring bushing.

Do not use spacers between the hoist ring bushing and the workpiece surface.

When installing in soft metal, such as aluminum, the minimum effective thread engagement should be two times the diameter of the thread.

Always *tighten the bolt to the proper torque value*, which is stamped on the Hoist Ring.

The belt might loosen during use. *Re-tightening the bolt to the required torque must be done whenever it loosens.* The proper tightening torque is stamped on the Hoist Ring.

When lifting, apply force gradually. **DO NOT APPLY SHOCK LOADS.**



© 2009 MOLDERS CHOICE, Inc.

24 Hour Service - 7 Days a week  
**1-800-809-4623**

WebSite: [www.molderschoice.com](http://www.molderschoice.com) • Email: [molders@molderschoice.com](mailto:molders@molderschoice.com)