

# ORDER FORM FOR DRAWER TYPE MAGNETS

This is an order

This is a request for quotation

Company: \_\_\_\_\_ Phone: \_\_\_\_\_

Name: \_\_\_\_\_ Fax: \_\_\_\_\_

Address: \_\_\_\_\_

City/State/Zip: \_\_\_\_\_

Your P.O. Number: \_\_\_\_\_ Date: \_\_\_\_\_

**Optional Equipment**

With slide gate shut-off

With tapped hole for liquid dispensing system

With purge hopper R.H. Side

With purge hopper L.H. Side

With discharge dump tube

Other \_\_\_\_\_

\* All bolt patterns falling inside the housing wall will be tapped threads unless shut-off ring interferes with the bolt pattern, in which case studs will be used.

\* All bolt patterns falling on housing wall will require threaded studs (1-1/4" lg. is standard) unless otherwise requested. If tapped holes are required, a thicker flange may be provided at an extra charge (rule of thumb: thread depth equals thread diameter).

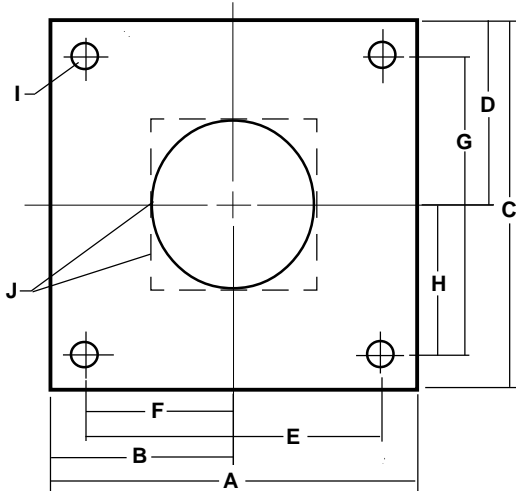

**BOTTOM FLANGE OPERATOR SIDE (FRONT)**

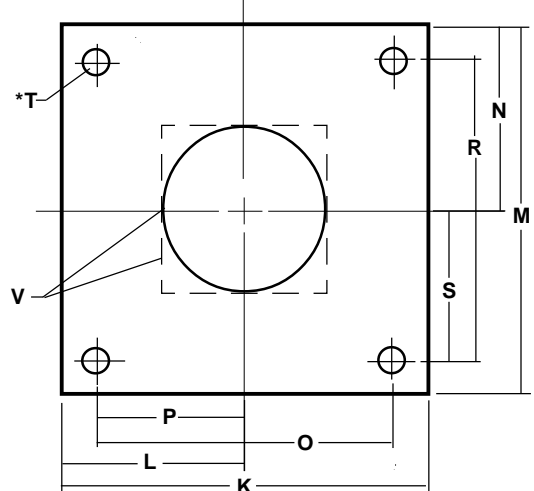

**TOP FLANGE OPERATOR SIDE (FRONT)**

A: \_\_\_\_\_ I: \_\_\_\_\_ (Bolt Size Used)  
 B: \_\_\_\_\_ J - Opening \_\_\_\_\_  
 C: \_\_\_\_\_ Round: \_\_\_\_\_  
 D: \_\_\_\_\_ Square: \_\_\_\_\_  
 E: \_\_\_\_\_ Rectangle: \_\_\_\_\_  
 F: \_\_\_\_\_ Front To Back: \_\_\_\_\_  
 G: \_\_\_\_\_ Side To Side: \_\_\_\_\_  
 H: \_\_\_\_\_

K: \_\_\_\_\_ \*T: \_\_\_\_\_  Threaded Holes  
 L: \_\_\_\_\_ (Thread Size Used)  Studs  
 M: \_\_\_\_\_ V - Opening \_\_\_\_\_  
 N: \_\_\_\_\_ Round: \_\_\_\_\_  
 O: \_\_\_\_\_ Square: \_\_\_\_\_  
 P: \_\_\_\_\_ Rectangle: \_\_\_\_\_  
 R: \_\_\_\_\_ Front To Back: \_\_\_\_\_  
 S: \_\_\_\_\_ Side To Side: \_\_\_\_\_

Make of Press \_\_\_\_\_ Serial No. \_\_\_\_\_

Model \_\_\_\_\_ Screw Size \_\_\_\_\_ Ounce \_\_\_\_\_

Make of Hopper \_\_\_\_\_ Hopper Capacity \_\_\_\_\_ Lbs \_\_\_\_\_

© 2013 MOLDERS CHOICE, Inc.



**24 Hour Service - 7 Days a week**  
**1-800-809-4623**  
 WebSite: [www.molderschoice.com](http://www.molderschoice.com) • Email: [molders@molderschoice.com](mailto:molders@molderschoice.com)