

BARREL FRONT END CAPS

Smooth internal bore prevents material degradation
Precision machined for accurate seating of nozzle

Available in:

- 4140 Alloy Steel
- H13
- Nitralloy / Nitrided
- Chrome Plate

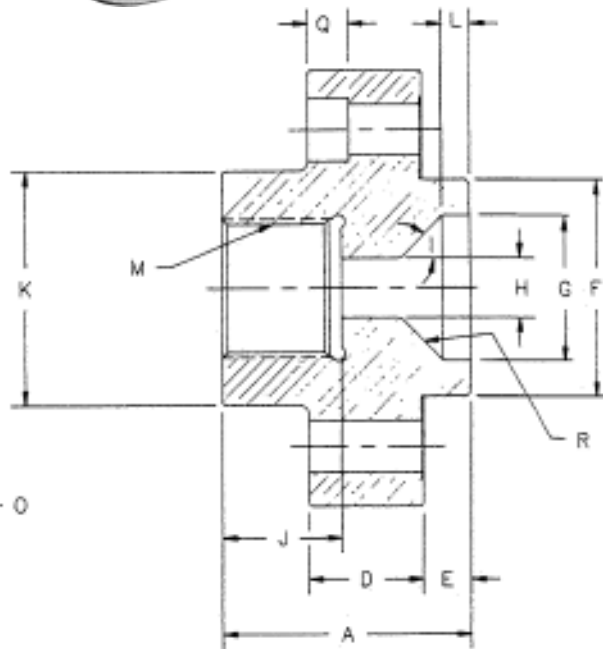
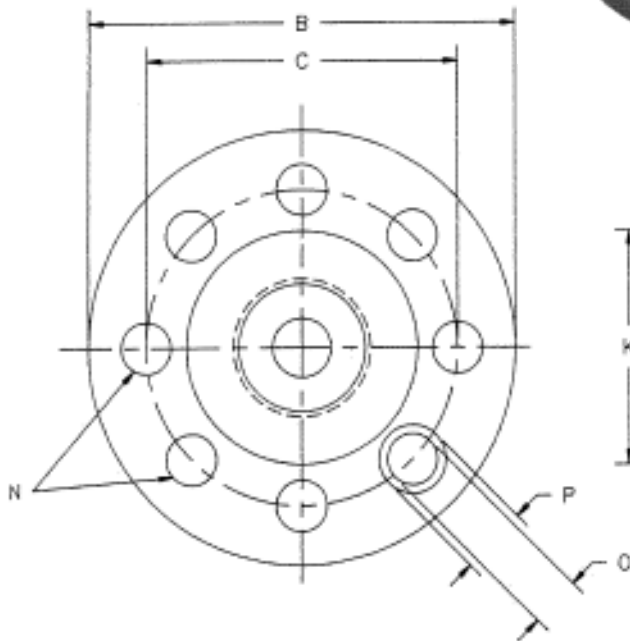

- A. Overall Length
- B. Flange Diameter
- C. Bolt Circle Diameter
- D. Flange Width
- E. Length of Pilot
- F. Pilot Diameter
- G. Rear Opening
- H. Bore Diameter
- I. Cone Angle

- J. Depth of Female Thread
- K. Nozzle Support Diameter
- L. Depth of Straight Bore
- M. Thread Type
- N. Number or Bolt Holes
- O. Bolt Hole Diameter
- P. Counter Bore Diameter (if any) ...
- Q. Counterbore Depth (if any)
- R. Surface Treatment

Indicate thermocouple hole position, depth and thread size

Any Make or Model End Cap can be made to your Sample or Drawing

©2013 MOLDERS CHOICE, Inc.



24 Hour Service - 7 Days a week
1-800-809-4623
 WebSite: www.molderschoice.com • Email: molders@molderschoice.com